



Top End[®] Eliminator OSR U Cage

UK Dealer Prescription Form January 2012

For accuracy of ordering, please fax along with the Eliminator order form to
 Invacare Customer Service on 01656 776220 or E Mail your order to ordersuk@invacare.com

www.topendwheelchair.co.uk

Account Name _____ Customer Name _____ Order Date _____

Account Number _____ PO Number _____ Tel Number _____ Fax Number _____

Address _____

Town _____ City _____ PostCode _____

1. Upper Frame Width _____
 2. Lower Frame Width _____
 3. Knee Width _____
 4. Knee Height _____
 5. Knee Depth (18" Std) _____
 6. Axle Position _____
 7. Rear Seat Height _____
 8. Camber 11° 12° 13° 15°
 9. Overall Length 64" 66"
 68" 70" 72" 74" 76"
 10. Rear Wheel Size 700c 26"
 11. Track Control Bottom Mount
 (Standard)
 Top Mount *
- * Not available on overall lengths less than 70"
11. Rear Wheel Type Zipp
 Corima Tri-Spoke Std

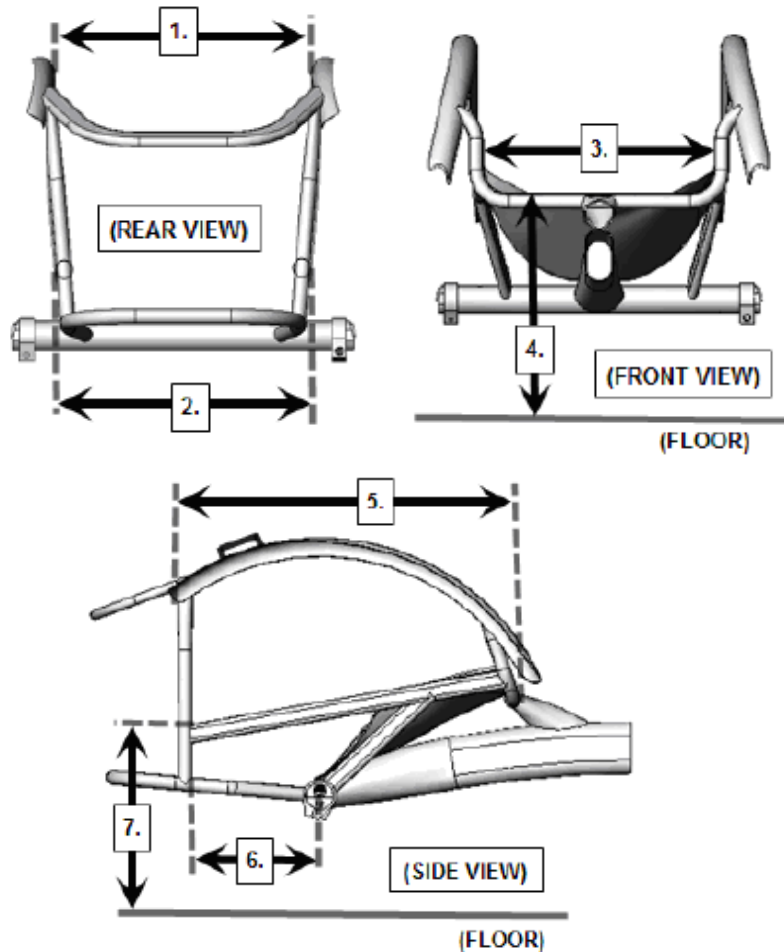

Invacare Ltd, Pencoed Technology Park, Pencoed, Bridgend, CF35 5AQ
 Tel: 01656 776222 Fax: 01656 776220 Email: ordersuk@invacare.com

Subject to Invacare's terms and conditions. Invacare reserve the right to alter specification without prior notice