

küschall[®]
designed for life



küschall[®] *Champion*

Active wheelchair

CE

User manual

 This product complies with Directive 93/42/
EEC concerning medical devices.

© Kuschall AG, Switzerland

Every effort has been made to ensure that the contents of this publication are fully up-to-date at the time of going to print. As part of its ongoing improvement of products, Kuschall® AG reserves the right to modify existing models at any time. Kuschall® dealers will be notified of any such modifications. Any use of this publication, or of parts thereof, as well as any reproduction of images, must have the written consent of Kuschall® AG.

kuschall® is a registered trademark.

Contents

1	General	5		
1.1	Information about the User Manual	5	4.10	Cane holder
1.2	Symbols	5	4.11	Seat cushion
1.3	Guarantee	5	4.12	Accessories
1.4	Service life	6	5	Set-up
1.5	Copyright protection	6	6	Using the wheelchair
2	Safety	7	6.1	Safety information
2.1	Safety information	7	6.2	Braking during use
2.2	Correct use	7	6.3	Getting in and out of the wheelchair
2.3	Safety devices	8	6.4	Driving and steering the wheelchair
3	Technical data	9	6.5	Negotiating steps and kerbs
3.1	Dimensions and weight	9	6.6	Going up and down stairs
3.2	Environmental conditions	10	6.7	Negotiating ramps and slopes
3.3	Tyre pressure	10	6.8	Stability and balance when seated
3.4	Identification label	10	7	Transport
4	Components and their function	11	7.1	Safety information
4.1	Overview	11	7.2	Folding and unfolding the wheelchair
4.2	Parking brakes	12	7.3	Removing and fitting the rear wheels
4.3	Backrest cover	13	8	Maintenance
4.4	Stabilising bar for the back (optional)	14	8.1	Maintenance schedule
4.5	Push handles	14	8.2	Cleaning
4.6	Side rest, infinitely height adjustable (optional)	16	8.3	Disinfection
4.7	Antitipper	16	9	Troubleshooting
4.8	Transit wheels	17	9.1	Identifying and repairing faults
4.9	Tipper aid	18		

10 After use	40
10.1 Re-use	40
10.2 Disposal	40

1 General

1.1 Information about the User Manual

Thank you for choosing a Küschall® wheelchair.

This User Manual contains important information about using the wheelchair. In order to ensure safety when using your wheelchair, read the User Manual carefully and follow the safety information.

The equipment of your wheelchair may differ from the descriptions and diagrams given here due to the wide range of models available.

1.2 Symbols

Warnings

In this User Manual warnings are indicated by symbols. The warning symbols are accompanied by a heading that indicates the severity of the danger.



WARNING

Indicates a hazardous situation that could result in serious injury or death if it is not avoided.



CAUTION

Indicates a hazardous situation that could result in minor or slight injury if it is not avoided.



IMPORTANT

Indicates a hazardous situation that could result in damage to property if it is not avoided.

Tips and recommendations



Gives useful tips, recommendations and information for efficient, trouble-free use.

1.3 Guarantee

General conditions

Küschall AG guarantees that their wheelchairs are free from defects and are fully functional. The guarantee covers all faults and defects which are verifiably attributable to faulty construction, substandard materials or poor workmanship. Guarantee claims against Küschall AG may only be made by the distributor and not by the wheelchair user.

Limitation of liability

The guarantee does not cover normal wear and tear, the consequences of improper handling or damage, poor maintenance and incorrect assembly or commissioning by the purchaser or a third person or faults which are attributable to circumstances beyond our control. The

guarantee is voided if modifications are made to the wheelchair which were not authorised and not performed by the specialist dealer or if inappropriate spare parts are used. The Küschall AG warranty does not cover consequential costs arising from the rectification of defects such as freight and travel expenses, labour costs, fees etc.

Term of the guarantee

The term of the guarantee is 24 months. The frame is guaranteed for 5 years. Wearing parts are not covered by the guarantee.

1.4 Service life

We estimate that the Küschall® wheelchair has a service life span of five years. It is difficult to state the exact length of the service life of our products, and the length stated is an estimated average life span based on normal use.

The life span may be considerably longer if the wheelchair is used to a limited extent, and if it is used with care, maintained and handled properly. The life span may be shorter if the wheelchair is subjected to extreme use.

1.5 Copyright protection

This User Manual is protected by copyright. It may not be reprinted or copied or transferred to third parties in part or in full without the prior written consent of the manufacturer.

2 Safety

This section contains important safety information for the protection of the wheelchair user and assistant and for safe, trouble-free use of the wheelchair.

2.1 Safety information



WARNING! Risk due to driving style being unsuitable for the conditions

There is a risk of skidding on wet ground, gravel or uneven terrain.

Always adjust your speed and driving style to the conditions (weather, surface, individual ability, etc.).



WARNING! Risk of injury

In a collision you could sustain injury to parts of your body that extend beyond the wheelchair (e.g. feet or hands).

- Avoid an unbraked collision
- Never drive into an object head-on
- Drive carefully through narrow passages.



WARNING! Risk due to wheelchair being out of control

At high speed you could lose control of your wheelchair and overturn.

- Never exceed a speed of 7 km/h.
- Avoid collisions in general.



CAUTION! Risk of burning

The wheelchair components can heat up when exposed to strong sunlight.



CAUTION! Risk of getting fingers caught

There is always a risk of getting, e.g. fingers or arms, caught in the moving parts of the wheelchair.

- Make sure when activating the folding or insertion mechanisms of moving parts, such as the removable axle of the rear wheel, folding backrest or antitipper, that nothing becomes caught.

2.2 Correct use

The wheelchair is propelled manually and should only be used for independent or assisted transport of a disabled person with mobility difficulties. When used without an assistant, it should only be used by persons who are physically able to use the wheelchair safely (e.g. to propel themselves,

steer, brake). The wheelchair should only be used on level ground and accessible terrain, as well as indoors.



WARNING!

Any other or incorrect use of the wheelchair could lead to hazardous situations.

2.3 Safety devices



WARNING! Risk of accidents











Safety devices that are incorrectly set or no longer working (brakes, antitipper) can cause accidents.
- Always check that the safety devices are working before you use the wheelchair and have them checked regularly by the specialist dealer.

The functions of the safety devices are described in Section 4 – *Components and their function*.

The wheelchair has been tested in accordance with EN 12183. It includes a test for flammability.

3 Technical data

3.1 Dimensions and weight

	Seat width (SB) 340–460 mm		Seat depth (ST) 340–460 mm
	Seat height front (SHv) 450–540 mm		Lower leg length (UL) 350–500 mm
	Seat height rear (SHh) 390–490 mm		Backrest height (RH) 300–465 mm
	Seat angle (SW) variable 20–10 mm		Backrest angle (RW) 79°–97°
	Total width (GB) ¹⁾ 530–650 mm		Total length (GL) ²⁾ 850–935 mm
	Weight ³⁾ 11.5 kg		Maximum user weight 120 kg

¹⁾ Total width = Seat width + 19 cm at 3° wheel camber

²⁾ Depending on seat angle, lower leg length, rear wheel and position foot rest

³⁾ With standard configuration, may vary (+/-)

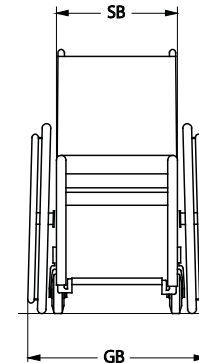
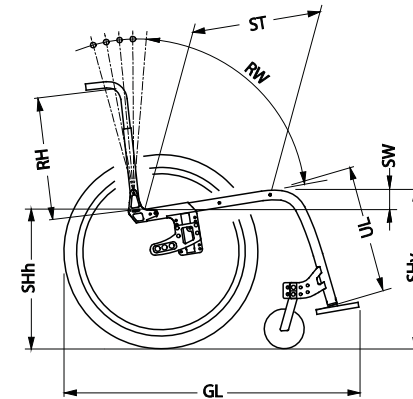

3.2 Environmental conditions

Do not expose the wheelchair to temperatures below -20°C or above 40°C.

3.3 Tyre pressure

The ideal pressure depends on the tyre type:

Tyre	Max. pressure		
Low-resistance tyre	7 bar	700 kPa	101 psi
Treaded tyre (marathon)	7.5 bar	750 kPa	108 psi
Slick tyres (speed run)	10 bar	1000 kPa	145 psi
Mountain bike tyre	4 bar	400 kPa	58 psi

3.4 Identification label

The identification label is attached to the frame of your wheelchair and gives the following information:



- ① Manufacturer's address
- ② Product description
- ③ Date of manufacture
- ④ Instruction to read the User Manual
- ⑤ Maximum user weight
- ⑥ Instruction that this wheelchair is not designed for passenger transport in vehicles
- ⑦ Serial number
- ⑧ Warning that this is an active wheelchair and can tip backwards.

4 Components and their function

4.1 Overview



- ① Back
- ② Rear wheel with handrim
- ③ Quick release axle
- ④ Folding mechanism
- ⑤ Front wheel fork with front wheel
- ⑥ Footrest
- ⑦ Frame
- ⑧ Parking brake
- ⑨ Seat cushion
- ⑩ Clothes-guard

Short description

The Küschall Champion is a folding active wheelchair with a horizontal folding mechanism.



The equipment of your wheelchair may differ from the picture as each wheelchair is manufactured individually to the specifications in the order.

4.2 Parking brakes

The parking brakes are used to immobilise the wheelchair when it is stationary to prevent it from rolling away.



WARNING! Risk of overturning if you brake sharply

If you apply the parking brakes while you are moving, the direction of movement can become uncontrollable and the wheelchair may stop suddenly, which can lead to a collision or to you falling out.

- Never apply the parking brakes while you are moving.



WARNING! Risk of overturning

The parking brakes will not operate correctly unless there is sufficient air in the tyres.

(→ Section 3 – Tyre pressure)

Standard push brake

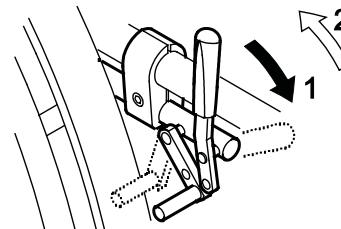

- 1** To apply the brake, push the brake lever forwards as far as possible.
- 2** To release the brake, pull the brake lever backwards.

Pull brake

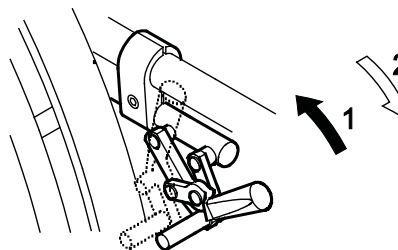

- 1** To apply the brake, pull the brake lever backwards as far as possible.
- 2** To release the brake, push the brake lever forwards.

Performance brake

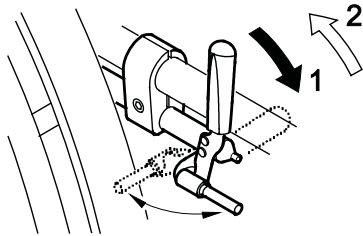

- 1 To apply the brake, push the brake lever forwards as far as possible.
- 2 To release the brake, pull the brake lever backwards.

Active brake

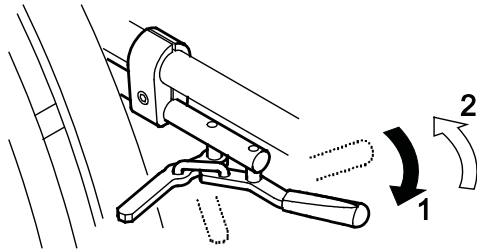

- 1 To apply the brake, pull the brake lever forwards beside or between your knees as far as possible.
- 2 To release the brake, push the brake lever backwards beside or between your knees.

4.3 Backrest cover

You can adjust the tension of the backrest cover as required.

Adjusting the backrest cover

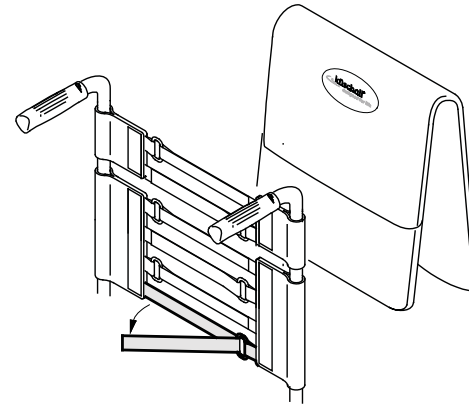

- Remove the backrest cushion.
- Loosen the Velcro® tapes on the rear of the backrest cover by simply pulling on them.
- Tighten or loosen the tapes as required then reattach them.

! IMPORTANT

Do not overtighten the bands; this is to ensure that the geometry of the wheelchair is not changed.

- ! **IMPORTANT**
If the bands are set very loose, the tipping point of your wheelchair is changed for the worse.
- ! **IMPORTANT**
Only ever tighten the belts when the wheelchair is unfolded.

4.4 Stabilising bar for the back (optional)

An optional stabilising bar is available to increase the rigidity of the backrest on wheelchairs with large back heights or widths.

- ! **IMPORTANT**
Do not use the stabilising bar to lift or push the wheelchair. It could break.
- ! **IMPORTANT**
Release the stabilising bar before folding the wheelchair.

Releasing the stabilising bar

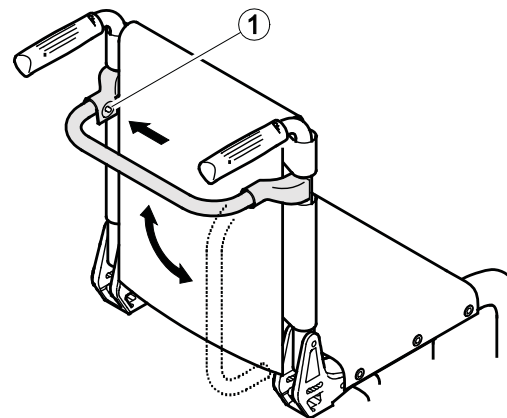

- Push the spring pin ① on the fastening on the left-hand side and swivel the stabilising bar downwards.

The stabilising bar can also be completely removed, by pushing the spring pins on both sides. The stabilising bar can then be taken off.

4.5 Push handles

- ! **IMPORTANT**
Always check the push handles before using the wheelchair, as to whether the hand grips are secure, cannot be turned and cannot be pulled off.

Foldable push handles (optional)

Foldable push handles are used when the push handles are only required occasionally.

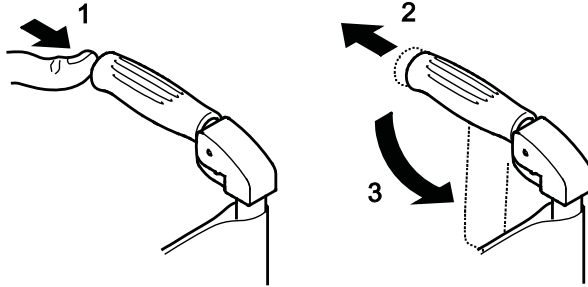

- To fold down the push handles, hold the wheelchair with one hand. Grip the push handle with the other and using your thumb activate the release that is concealed under the plastic. (1)
- At the same time pull the push handle backwards (2) and fold it down (3).
- To fold the push handles up, bring the push handle into the horizontal position until it engages.

IMPORTANT

- ! Make sure that the push handle does actually engage so that it does not accidentally fold down while pushing the wheelchair.

Height adjustable, angled push handles (optional)

The infinitely height adjustable push handles allow any assistant to adjust the handles to a comfortable level.

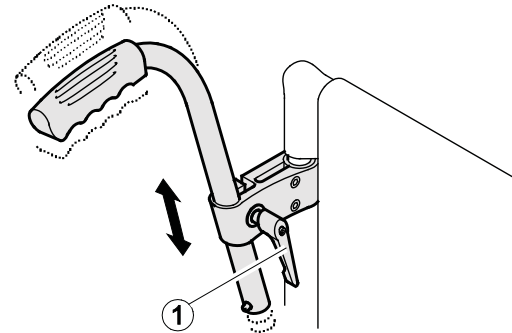

- To set the height of the push handles, loosen the bolt ①, push the handle to the desired position and tighten the bolt again.

4.6 Side rest, infinitely height adjustable (optional)

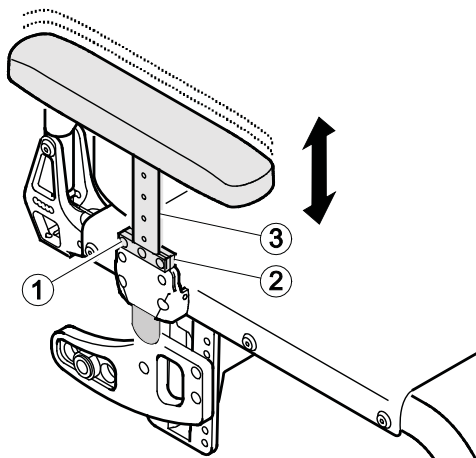

Removing

- Pull the side rest by the arm cushion out of the holder.
- To adjust how easy or difficult it is to pull the side rest out of the holder, change the degree to which the screws are tightened.

Fitting

- Push the side rest into the holder.

Adjusting the height

- Loosen the screw ① of the retaining plate ②.

- Move the armrest upwards or downwards until you reach the desired height.
- Tighten the screw ①.
- Perform the setting on both sides.

4.7 Antitipper

An antitipper prevents the wheelchair from tipping backwards.



WARNING! Risk of overturning

Antitippers that are incorrectly set or no longer working can lead to overturning.

- Always check that the antitipper is working before using the wheelchair and have it set or readjusted by a specialist dealer when required.

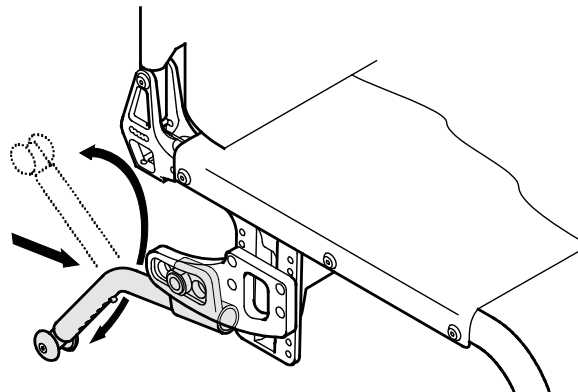

Activating the antitipper

- Push the antitipper to the front against the spring and swivel it through 180° until it engages in the lower position.



CAUTION! Risk of tipping

An activated antitipper can catch when negotiating a step or an edge.
- Always deactivate the antitipper before driving over a step or kerb.

Deactivating the antitipper

- Push the antitipper to the front against the spring and swivel it through 180° until it engages in the upper position.

4.8 Transit wheels



WARNING!

When using transit wheels, the parking brakes no longer have any effect and you cannot control your wheelchair via the handrims.

If your wheelchair is too wide for certain applications, e.g. trains/aeroplanes, narrow passageways, narrow doors, the transit wheels can be used.

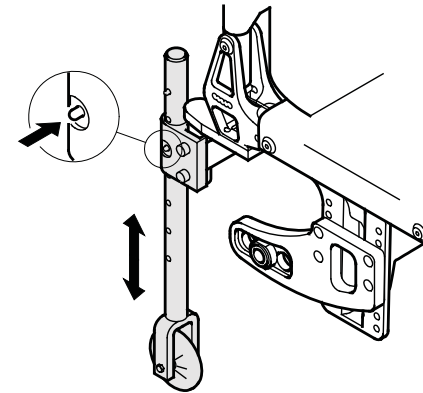

Switching to transit wheels

- Lower the transit wheels into the operating position. To do this, press the pin inwards until you can pull the tube down.
- Press the second pin in.
- Pull the tube further downwards until the pin engages into the slot.
- Move the wheelchair to a stable object (door frame, heavy table), which you can use for support and hold onto it firmly with one hand.
- Tilt the wheelchair until the rear wheel on the opposite side rises off the floor.

Components and their function

küschall® Champion

- Remove the rear wheel (→Section 7 – *Removing the rear wheels*).
- Repeat the process on the other side.



Prior to removing the rear wheels, the distance between the lowered transit wheels and the floor should not be more than 2 cm.

Switching from transit wheels to rear wheels

- Move the wheelchair to a stable object, which you can use for support and hold onto it firmly with one hand.
- Tilt the wheelchair until the transit wheel on the opposite side rises slightly off the floor.
- Fit the rear wheel back onto the removable axle (→Section 7 – *Fitting the rear wheels*).
- Bring the transit wheels back into the inactive position.
- Repeat the process on the other side.

4.9 Tipper aid

With the tipper aid, an assistant can tip the wheelchair more easily, in order to navigate steps for example.

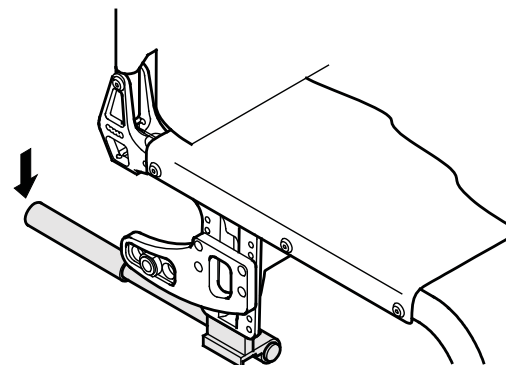

- Hold the wheelchair by the push handles.
- Press the tipper aid with your foot and hold the wheelchair in the tipped position until you have overcome the obstacle.



CAUTION! Risk of overturning

The tipper aid must not project beyond the external diameter of the rear wheel.

4.10 Cane holder

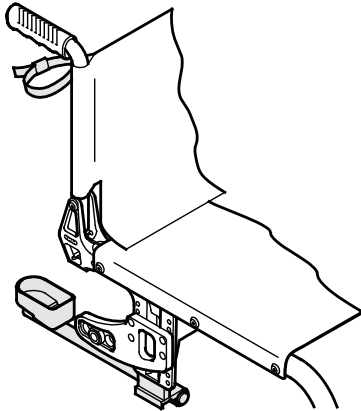

- Place the cane in the holder.
- Fix the top of the cane to the backrest.



CAUTION! Risk of overturning

The cane holder must not project beyond the external diameter of the rear wheel.

4.11 Seat cushion

A suitable cushion is needed to provide an even pressure distribution on the seat.

4.12 Accessories

Securing strap

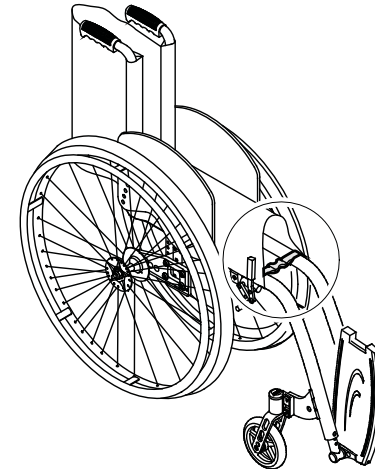

The securing strap is used to secure the wheelchair when folded. This prevents the wheelchair from unfolding accidentally (e.g. during transport).

- Release both sides of the seat bag from the clip fastener (if fitted).
- Fold the wheelchair (→Section 7) and clip both ends of the securing strap together.

Safety belt

Your wheelchair can be fitted with a safety belt which will prevent you from falling out of the wheelchair.

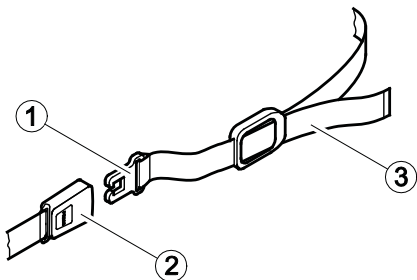

Fitting a safety belt

IMPORTANT

! Safety belts must be fitted by a specialist dealer.

- Remove the backrest cover and attach the Velcro® fastener to the backrest at the required height. Ensure that the fastener is at the front.

Opening the safety belt

- Push in the PRESS button and pull the catch ① out of the buckle ①. The safety belt opens.

Closing the safety belt

- Push the catch ① into the buckle ①
- Pull the belt ③ until you are held securely in the wheelchair.

Air pump

The air pump is fitted with a universal valve connection.

- Remove the dust cap from the valve connection.
- Push the valve connection onto the open valve on the wheel and pump the wheel up.

Wheelchair carry bag (optional)

Your folded wheelchair can be stored in a carry bag to keep it safe and clean during transport.

Passive illumination

You can attach reflectors to the rear wheels.

5 Set-up



CAUTION!

Before using the wheelchair, check its general condition and its main functions. (See Section 8 – *Maintenance*)

Your specialist dealer will supply your wheelchair ready for use. Your dealer will explain the main functions and ensure that the wheelchair meets your needs and requirements .

6 Using the wheelchair

6.1 Safety information



CAUTION! Risk of crushing

There may be a very small gap between the rear wheel and the mudguard with the risk that you could trap your fingers.

- Ensure that you always propel your wheelchair using the handrims only.



CAUTION! Risk of crushing

There may be a very small gap between the rear wheel and the parking brake with the risk that you could trap your fingers.

- Ensure that you always propel your wheelchair using the handrims only.



WARNING! Risk of accidents

Uneven tyre pressure can have a huge effect on handling.

- Check the tyre pressure before each journey.

6.2 Braking during use

Whilst you are moving, you brake by transferring force to the handrim with your hands.

- Hold the handrims and press evenly with both hands until the wheelchair stops.



WARNING! Risk of overturning if you brake sharply

If you apply the parking brakes while you are moving, the direction of movement can become uncontrollable and the wheelchair may stop suddenly, which can lead to a collision or to you falling out.

- Never apply the parking brakes while you are moving.



CAUTION!

If you brake for a long time, a lot of frictional heat is produced at the handrims (especially MaxGrepp and Supergripp). You could burn your hands.

- Wear suitable gloves.

Braking with an assistant

With an assistant's brake (drum brake) an assistant can brake the wheelchair while it is moving. The assistant's brake can also be used as a parking brake.

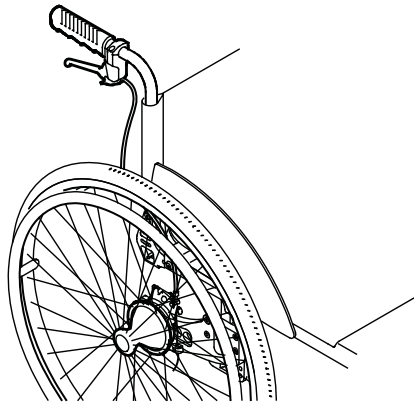

- To brake, pull the brake lever on the push handle.
- To park, pull the brake lever firmly until the safety lever engages.
- To release, pull the brake lever and release the safety lever underneath the brake lever.

6.3 Getting in and out of the wheelchair



WARNING! Risk of overturning

There is a high risk of overturning during the transfer.

- Only get in and out without assistance if you are physically able to do so.



WARNING! Risk of overturning

The wheelchair could tip forwards if you stand on the footrest.

- Never stand on the footrest when getting in and out.



CAUTION!

If you release or damage the brakes the wheelchair could roll away out of control.

- Do not support yourself on the brakes when getting in and out.



IMPORTANT!

The mudguards and armrests could become damaged.

- Never sit on the mudguards or armrests when getting in and out.

- Apply the parking brakes.

- Fold the footrests up or swing them to the side (depending on design).
- Place your feet on the ground.
- Hold the wheelchair and, if necessary, also hold a fixed object in the vicinity.

6.4 Driving and steering the wheelchair

You drive and steer the wheelchair using the handrims.

Before driving without an assistant you must find your wheelchair's tipping point.



WARNING! Risk of tipping

The wheelchair can tip backwards if it is not fitted with an antitipper. When finding the tipping point, an assistant must stand immediately behind the wheelchair to catch it if it tips over. To prevent tipping, install an antitipper device.



WARNING! Risk of tipping

The wheelchair can tip forwards.

- When setting up your wheelchair, test its behaviour in terms of tipping forward and adjust your driving style accordingly.



CAUTION!

A heavy load hanging on the backrest can affect the wheelchair's centre of gravity.
- Change your driving style accordingly.

Finding the tipping point

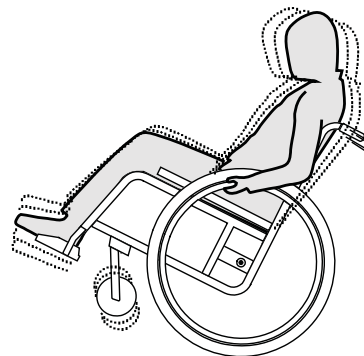

- Release the brake.
- Roll forwards a short distance, grasp both handrims firmly and pull backwards with a slight kick.
- The shift in weight and steering in opposite directions with the handrims will enable you to identify the tipping point.

6.5 Negotiating steps and kerbs



WARNING! Risk of overturning

When negotiating steps you could lose your balance and tip the wheelchair over.

- Always approach steps and kerbs slowly and carefully.
- Do not go up or down steps that are higher than 25 cm.



CAUTION

An activated antitipper prevents the wheelchair from tipping backwards.

- Deactivate the antitipper before going up or down steps or kerbs.

With an assistant



Going down a step

- Move the wheelchair right up to the kerb and hold the handrims.
- The assistant should hold both push handles, place one foot on the tipper aid (if installed) and tilt the wheelchair backwards so that the front wheels lift off the ground.
- The assistant should then hold the wheelchair in this position, push it carefully down the step and then tilt it forwards until the front wheels are back on the ground.

Going up a step

- Move the wheelchair backwards until the rear wheels touch the kerb.
- The assistant should tilt the wheelchair using both push handles so that the front wheels lift off the ground, then pull the rear wheels over the kerb until the front wheels can be placed back on the ground.

Without an assistant



WARNING! Risk of tipping

When going down a step without an assistant you could tip over backwards if you cannot control your wheelchair.

- First learn how to go down a step with an assistant.
- Learn how to balance on the rear wheels (→ Section 6 – *Driving and steering the wheelchair*).

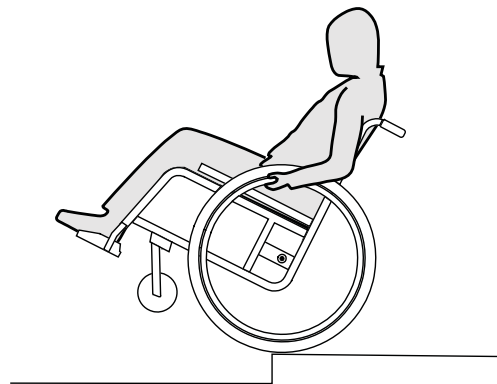

Going down a step

- Move the wheelchair right to the kerb, lift the front wheels and keep the wheelchair balanced.
- Now slowly roll both rear wheels over the kerb. While doing this, hold the handrims firmly with both hands until the front wheels are back on the ground.

6.6 Going up and down stairs



WARNING! Risk of overturning

When negotiating stairs you could lose your balance and overturn your wheelchair.

- Always use 2 assistants when negotiating stairs with more than one step.



- You can go up and down stairs by taking them one step at a time, as described above. The first assistant should stand behind the wheelchair holding the push handles. The second assistant should hold a solid part of the front frame to steady the wheelchair from the front.

6.7 Negotiating ramps and slopes



WARNING! Risk due to wheelchair being out of control

When negotiating slopes or gradients your wheelchair could tip backwards, forwards or sideways.

- Always have an assistant behind the wheelchair when approaching long slopes.
- Avoid lateral slopes.
- Avoid slopes of more than 7°.
- Avoid jerking when changing direction on a slope.



CAUTION!

Your wheelchair could run away even on slightly sloping ground if you do not control it using the handrims.

- Use the parking brakes if your wheelchair is stationary on sloping ground.

Going up slopes

To go up a slope, you must create some momentum, keep up the momentum and control the direction at the same time.

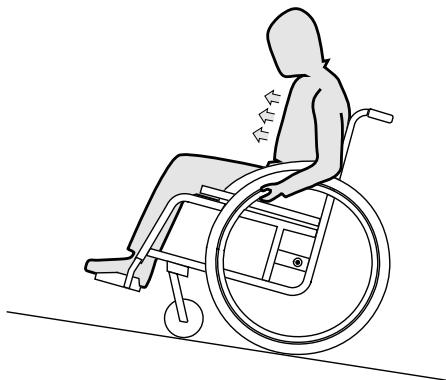

- Bend your upper body forwards and propel the wheelchair with quick, powerful strokes on both handrims.

Going down slopes

When going down slopes, it is important to control your direction and particularly your speed.

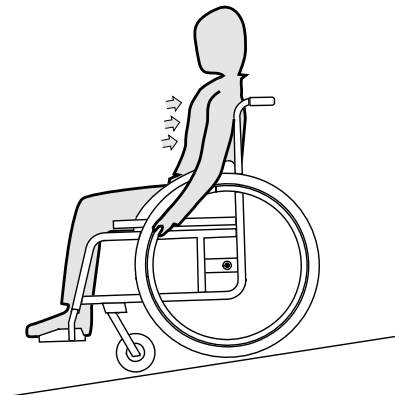

- Lean back and carefully allow the handrims to run through your hands. You should be able to stop the wheelchair at any time by gripping the handrims.



CAUTION!

If you brake for a long time, a lot of frictional heat is produced at the handrims (especially MaxGrepp and Supergripp). You could burn your hands.
- Wear suitable gloves.

6.8 Stability and balance when seated

Some everyday activities and actions require you to lean forwards, sideways or backwards out of the wheelchair. This has a major effect on the wheelchair's stability. To keep your balance at all times, proceed as follows:

Leaning forwards



WARNING! Risk of falling out

If you lean forwards out of the wheelchair you could fall out of it. Never bend too far forwards and do not shift forwards in your seat to reach an object. Do not bend forwards between your knees to pick up something off the floor.



- Point the front wheels forwards.
(To do this, move your wheelchair forwards slightly then back again.)
- Apply both parking brakes.
- When leaning forwards your upper body must remain over the front wheels.

Reaching backwards



WARNING! Risk of falling out

If you lean too far backwards you could tip your wheelchair over. Do not lean out over the backrest. Use an antitipper device.

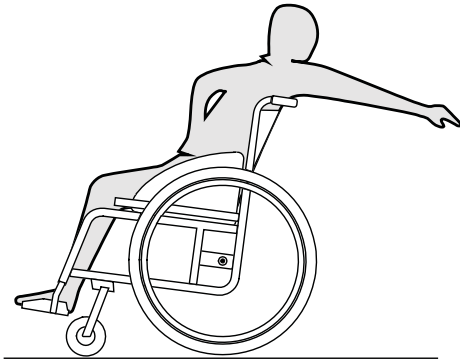

- Point the front wheels forwards.
(To do this, move your wheelchair forwards slightly then back again.)
- Do not apply the parking brakes.
- When reaching backwards do not reach so far that you have to change your sitting position.

7 Transport

7.1 Safety information



WARNING! Risk of injury if wheelchair is not secured during transport

Your wheelchair is not designed for passenger transport in vehicles. You could suffer serious injury in an accident.

- During transport, sit in a correctly secured seat, not in the wheelchair.

IMPORTANT!

Excessive wear and abrasion could affect the strength of load-bearing parts.

- Do not pull your wheelchair across abrasive surfaces without the wheels fitted (e.g. pulling the frame over tarmac).

7.2 Folding and unfolding the wheelchair

Folding the wheelchair

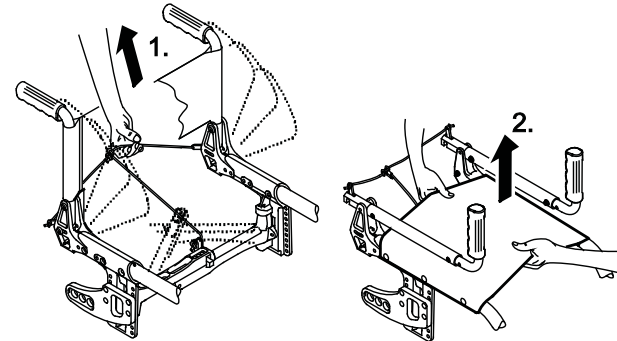

- Remove the seat cushion.
- If fitted, release the backrest stabilization bar by pressing the spring pin and swinging the bar downwards (→ Chp. 4 – *Stabilising bar*).
- Pull the pull-cord at the back of the wheelchair up and back (1.). The shears of the folding mechanism under the seat fold backward and the backrest folds forward.
- With both hands, pull the seat cover and the backrest cover upwards (2.). The wheelchair folds up completely.

Unfolding the wheelchair

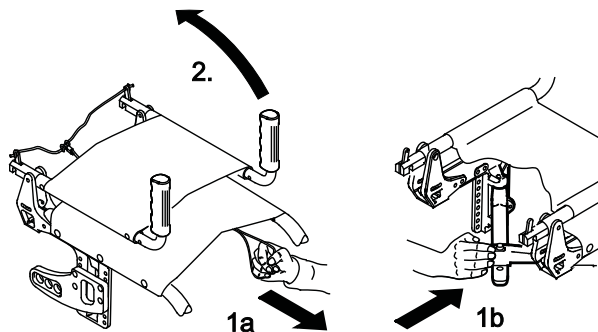

- Pull the cord on the front under the seat cover until the ratchet engages completely (1a.)

or

- push forward the shears until the ratchet engages completely by pressing the palm of your hand against the projecting part of the shears (1b).



CAUTION! Risk of getting fingers caught

There is a risk of getting your fingers caught between the parts of the shears.

- Therefore you should never clasp the shears with your fingers.

- Pull up the backrest at the push-handles until the ratchet bolts engage in the lateral supports (2.).

- If fitted, replace the backrest stabilization bar by swinging it upwards and locating the spring pin in its hole (→ Chp. 4 – Stabilising bar).

7.3 Removing and fitting the rear wheels



WARNING! Risk of overturning

If the removable axle of a rear wheel is not fully engaged, the wheel can become loose during use. This can lead to overturning.

- Always ensure that the removable axles are fully engaged whenever you fit a wheel.

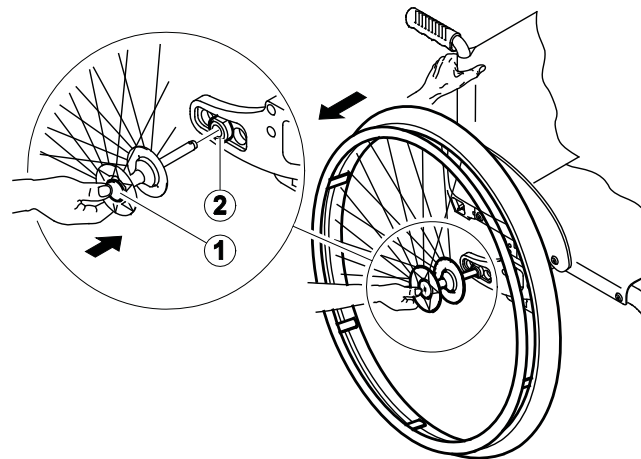

Removing the rear wheels

- Release the brakes.
- With one hand, hold the wheelchair upright.
- With the other hand, hold the spokes around the wheel hub.
- Press the removable axle button ① with your thumb and hold it down. Keep it pressed and pull the wheel out of the adapter sleeve ②.

Fitting the rear wheels

- Release the brakes.
- With one hand, hold the wheelchair upright.
- With the other hand, hold the spokes around the wheel hub.
- Press the removable axle button with your thumb and hold it down.
- Push the axle into the adapter sleeve ② up to the stop.
- Release the removable axle button and make sure that the wheel is secure.

8 Maintenance

8.1 Maintenance schedule

To ensure safe and reliable operation, carry out the following checks and maintenance regularly or have it carried out by another person.

	Weekly	Monthly	Annually
Check the tyre pressure	✓		
Check that rear wheels are seated correctly	✓		
Visual check		✓	
Clean the front wheels		✓	
Check bolts		✓	
Check spokes		✓	
Check parking brakes		✓	
Have wheelchair checked by the specialist dealer			✓

Check the tyre pressure

- Check the tyre pressure (→ Pressure table in Section 3 - *Technical data*).
- Inflate the tyres to the required pressure.
- Check the tyre tread at the same time.
- If necessary, change the tyres

Check that rear wheels are seated correctly

- Pull on the rear wheel to check that the removable axle is seated correctly. The wheel should not come off.
- If the rear wheels are not engaged properly, remove any dirt or deposits. If the problem persists, have the removable axles re-fitted by a specialist dealer.

Visual check

- Examine your wheelchair for loose parts, cracks or other defects.
- If you find anything, have your wheelchair checked immediately by a specialist dealer.

Clean the front wheels

- Check that the front wheels turn freely.
- Remove any dirt or hair from the front wheel bearings.

Check the bolts

Bolts can work loose through constant use.

- Check that the bolts are tight (on the front wheel supporter, footrest, seat cover, sides, adapter plate, backrest).
- Tighten any loose bolts.

IMPORTANT!

- ! Safety nuts and bolts lose their effectiveness as a result of repeated loosening and tightening.
- Safety nuts and bolts should be replaced by a specialist dealer.

Check the spoke tension

The spokes should not be loose or distorted.

- Loose spokes should be tightened by a specialist dealer.
- Broken spokes should be replaced by a specialist dealer.

Check the parking brakes

- Check that the parking brakes are positioned correctly.
The brake is set correctly if the brake shoe depresses the tyre by a few millimetres when the brake is applied.
- If you find that the setting is not correct, have the brakes correctly set by a specialist dealer.

IMPORTANT

- ! The parking brakes must be reset after replacing the rear wheels or changing their position.

Repairing or changing an inner tube

- Remove the rear wheel and release any air from the inner tube.
- Lift one tyre wall away from the rim using a bicycle tyre lever. Do not use sharp objects such as a screwdriver which could damage the inner tube.
- Pull the inner tube out of the tyre.
- Repair the inner tube using a bicycle repair kit or, if necessary, replace the tube.
- Inflate the tube slightly until it becomes round.
- Insert the valve into the valve hole on the rim and place the tube inside the tyre (the tube should lie right round the tyre with no creases).
- Lift the tyre wall over the edge of the rim. Start close to the valve and use a bicycle tyre lever. When doing this, check all the way round to ensure that the inner tube is not trapped between the tyre and the rim.
- Inflate the tyre to the maximum operating pressure.
Check that no air is escaping from the tyre.

Spare parts



All spare parts may be obtained from a Küschall specialist dealer.
A current list of spare parts is available on the internet at www.kueschall.com.

8.2 Cleaning

Your wheelchair will serve you well for many years if you clean it regularly.



IMPORTANT!

Sand and seawater can damage the bearings and steel parts can rust if the surface is damaged. Only expose the wheelchair to sand and seawater for short periods and clean it after every trip to the beach.

- Clean the cushions and metal parts with a soft, damp cloth.
- Dry the wheelchair carefully with a cloth after using it in the rain or in the shower.
- If the wheelchair is dirty, wipe off the dirt as soon as possible with a damp cloth and dry it carefully.



IMPORTANT!

Do not use coarse abrasives, aggressive cleaning products or high-pressure cleaners.

8.3 Disinfection

The wheelchair may be disinfected by spraying or wiping with tested, approved disinfectants.



The Robert Koch Institute has a list of currently approved disinfectants at <http://www.rki.de>.

9 Troubleshooting

Faults may arise as a result of daily use, adjustments or changing demands on the wheelchair. The table below shows how to identify and repair faults.



CAUTION!

Contact your specialist dealer immediately if you notice a fault with your wheelchair, e.g. a significant change in handling.



IMPORTANT!

Some of the actions listed must be carried out by an authorised specialist dealer. These are indicated. We recommend that *all* adjustments are carried out by a specialist dealer.

9.1 Identifying and repairing faults

Fault	Possible cause	Action
The wheelchair does not travel in a straight line	Incorrect tyre pressure on one rear wheel	Correct tyre pressure (→Section 3 - <i>Technical data</i>)
	Bearing block of the front wheel is not in a vertical position	Put bearing block in a vertical position (→specialist dealer)
	Front wheels not adjusted to same height	Position the front wheels such that they touch the floor at the same time (→specialist dealer)
	One or more spokes broken	Replace faulty spoke(s) (→specialist dealer)
	Spokes tightened unevenly	Tighten loose spokes (→specialist dealer)
	Front wheel bearings are dirty or damaged	Clean or replace the bearings (→specialist dealer)
	Rear wheels are off track	Change track (→specialist dealer)
The wheelchair tips backwards too easily	Rear wheels are mounted too far forwards	Mount the rear wheels further back (→specialist dealer)
	Seat angle too large	Mount the adapter plate lower on the side profile (→specialist dealer)
		Select a smaller front fork (→specialist dealer)
Back angle too large	Reduce the backrest angle (→specialist dealer)	
The brakes are gripping poorly or asymmetrically	Incorrect tyre pressure in one or both rear tyres	Correct the tyre pressure (→Section 3 – <i>Technical data</i>)
Rolling resistance is very high	Rear wheels are off track	Change track (→specialist dealer)
	Tyre pressure in rear tyres is too low	Correct the tyre pressure (→Section 3 – <i>Technical data</i>)

The front wheels wobble when moving fast	Too little tension in front wheel bearing block	Tighten the nut on the bearing block axle slightly (→specialist dealer)
The wheelchair is very difficult to unfold	Backrest cover is too tight	Loosen the Velcro bands of the backrest cover a little (→Section 4 - <i>Backrest cover</i>)
	Folding mechanism adjusted too hard	Adjust folding mechanism (→specialist dealer)

10 After use

10.1 Re-use

The wheelchair is suitable for re-use. The following actions should be taken:

- Cleaning and disinfection according to Section 8 - *Cleaning* in this manual.
- Inspection according to Chapter 8 - *Maintenance schedule* in this manual.
- The wheelchair should be adapted for the new user in accordance with the service documentation (available from the Küschall® distributor for your country, →end of this document).

10.2 Disposal

Be environmentally aware and dispose of your wheelchair properly. Disposal is subject to national and local regulations.



For correct disposal, contact your specialist dealer or ask your town or district council about local waste management companies.

küschall® distributors

Belgium & Luxemburg: Invacare nv • Autobaan 22 • B-8210 Loppem
Tel: (32) (0)50 83 10 10 • Fax: (32) (0)50 83 10 11 • belgium@invacare.com

Denmark: Invacare A/S • Sdr. Ringvej 37 • DK-2605 Brøndby
Tel: (45) (0)36 90 00 00 • Fax: (45) (0)36 90 00 01 • denmark@invacare.com

Deutschland: Invacare Aquatec GmbH • Alemannenstraße 10 • D-88316 Isny
Tel: (49) (0)75 62 7 00 0 • Fax: (49) (0)75 62 7 00 66 • info@invacare-aquatec.com

Deutschland: Ulrich Alber GmbH • Vor dem Weissen Stein 21 • D-72461 Albstadt-Tailfingen
Tel: (49) (0)74 32 2006 0 • Fax: (49) (0) 74 32 2006 299 • info@ulrich-alber.de

European Distributor Organisation: Invacare • Kleiststraße 49 • D-32457 Porta Westfalica
Tel: (49) (0)57 31 754 540 • Fax: (49) (0)57 31 754 541 • edo@invacare.com

España: Invacare SA • c/Areny s/n • Poligon Industrial de Celrà • E-17460 Celrà (Girona)
Tel: (34) (0)972 49 32 00 • Fax: (34) (0)972 49 32 20 • contactsp@invacare.com

France: Invacare Poirier SAS • Route de St Roch • F-37230 Fondettes
Tel: (33) (0)2 47 62 64 66 • Fax: (33) (0)2 47 42 12 24 • contactfr@invacare.com

Ireland: Invacare Ireland Ltd • Unit 5 Seatown Business Campus • Seatown Road • Swords • County Dublin – Ireland
Tel: (353) 1 810 7084 • Fax: (353) 1 810 7085 • ireland@invacare.com

Italia: Invacare Mecc San s.r.l. • Via dei Pini 62 • I-36016 Thiene (VI)
Tel: (39) 0445 38 00 59 • Fax: (39) 0445 38 00 34 • italia@invacare.com

Nederland: Invacare BV • Celsiusstraat 46 • NL-6716 BZ Ede
Tel: (31) (0)318 695 757 • Fax: (31) (0)318 695 758 • nederland@invacare.com • csede@invacare.com

Norge: Invacare AS • Grensesvingen 9 • Postboks 6230 • Etterstad • N-0603 Oslo
Tel: (47) (0)22 57 95 00 • Fax: (47) (0)22 57 95 01 • norway@invacare.com • island@invacare.com

Österreich: Invacare Austria GmbH • Herzog Odilostrasse 101 • A-5310 Mondsee
Tel.: (43) 6232 5535 0 • Fax.: (43) 6232 5535 4 • info@invacare-austria.com

Portugal: Invacare Lda • Rua Estrada Velha • 949 • P-4465-784 Leça do Balio
Tel: (351) (0)225 1059 46/47 • Fax: (351) (0)225 1057 39 • portugal@invacare.com

Sverige & Suomi: Invacare AB • Fagerstagatan 9 • S-163 91 Spånga
Tel: (46) (0)8 761 70 90 • Fax: (46) (0)8 761 81 08 • sweden@invacare.com • finland@invacare.com

Switzerland: Invacare AG • Benkenstrasse 260 • CH-4108 Witterswil
Tel.: (41) (0)61 487 70 80 • Fax.: (41) (0)61 487 70 81 • switzerland@invacare.com

United Kingdom: Invacare Limited • Pencoed Technology Park,
Pencoed, Bridgend CF35 5HZ • Switchboard Tel: (44) (0)1656 776 200, Fax: (44) (0)1656 776 201 •
Customer services Tel: (44) (0) 1656 776 222 • Fax: (44) (0) 1656 776 220



Küschall AG
Benkenstrasse 260
CH-4108 Witterswil
kueschall@invacare.com
www.kueschall.com

ENGLISH
2011-05
1512598