

Invacare Top End Force Handcycle - UK Price List and Order Form

For accuracy of ordering, please fax order to Invacare Customer Service on 01656 776220 or e-mail to: ordersuk@invacare.com

www.topendwheelchair.co.uk



Provider name: _____ Account number: _____
 PO number: _____
 Phone number: _____ Fax number: _____
 Address: _____

Customer name: _____ Phone number: _____
 Address: _____
 Ship to: Provider Customer (Order will be shipped to provider unless otherwise noted)

DATE:

QUOTE

ORDER

Manual Sport Wheelchair
 January 2012

- Please indicate your choice with a cross in this square
- Indicate that this option has no upcharge

Item	Description	Comments and/or non compatibilities information	Price
<input type="checkbox"/> FRC	Top End Force Handcycle	Reclining position	£3,400
<input type="checkbox"/> FRC5	Force Handcycle less front and rear wheels		£3,250
SEATING OPTIONS			
Seat width			
<input type="checkbox"/>	Seat width 14"		<input type="radio"/>
<input type="checkbox"/>	Seat width 15"		<input type="radio"/>
<input type="checkbox"/>	Seat width 16"		<input type="radio"/>
<input type="checkbox"/>	Seat width 17"		<input type="radio"/>
<input type="checkbox"/>	Seat width 18"		<input type="radio"/>
Wheel base			
<input type="checkbox"/>	Standard	Wheelbase 60"	Recommended for users taller than 5'6"
<input type="checkbox"/>		Wheelbase 57"	
CUSTOMER DETAILS			
	Height:		<input type="radio"/>
	Weight:		<input type="radio"/>
	Disability:		<input type="radio"/>
COMPONENTS CHOICES: SHIFTER / BRAKE / FRONT WHEEL DERAILEUR / CASSETTES PACKAGES			
Shifter / Brake / Front wheel derailleur packages			
<input type="checkbox"/>	Standard	Rapid-fire® brake / shifter with Shimano® XT Derailleur, KMC® chain	<input type="radio"/>
<input type="checkbox"/>	XLT53	SRAM® grip shifter, Paul® component brake lever and SRAM® X.O. Derailleur / SRAM hollow pin chain	£375
<input type="checkbox"/>	XLT54	SRAM® trigger shifter, Paul® component brake lever and SRAM® X.O. Derailleur / SRAM hollow pin chain	£428
Mounting position: Shifter / Brake Lever			
<input type="checkbox"/>	Standard	Right handle	<input type="radio"/>
<input type="checkbox"/>		Left handle	<input type="radio"/>
BRAKE CHOICE (includes brake and parking brake)			
<input type="checkbox"/>	Standard	Caliper-Cane Creek® SCR-3	<input type="radio"/>
<input type="checkbox"/>	XLT55	Caliper-Cane Creek® SL with titanium hardware	£102
<input type="checkbox"/>	XLT66	Disc brake	£187
FRONT WHEEL CASSETTE			
<input type="checkbox"/>	Standard	SRAM® 11-34	<input type="radio"/>
<input type="checkbox"/>	XLT58	SRAM® 11-23	£33
<input type="checkbox"/>	XLT59	SRAM® 11-26	£33
CHAIN RING CHOICE (operated by crank mounted shifter)			
<input type="checkbox"/>	Standard	48-39-24	<input type="radio"/>
<input type="checkbox"/>	XLT41	Chain ring option 53-39-28	£66
<input type="checkbox"/>	XLT47	Rotor® Q-Ring option 53-39-28	£380
HANDPEDAL SIZE			
Handpedals are made of lightweight aluminium and are ovalized to precisely fit the hand. The bearing which allow the pedal to rotate while pedaling are located in the crank set and not in the pedal, which makes this pedal very comfortable.			
<input type="checkbox"/>	Standard	Medium handpedal size (1 3/4")	<input type="radio"/>
<input type="checkbox"/>	XLT72	Small handpedal size (1 1/2")	£50
<input type="checkbox"/>	XLT73	Large handpedal size (2 1/4")	£50
<input type="checkbox"/>	XLT56	Power plate upgrade	£33

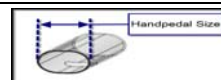

CRANK ARMS: TAPERED CRANK (choose length and width)				
Top End V crank set with integral pedal bearings are standard. Length of crank set depends on the length of the arms. To choose the width for the crank, consider the end user's shoulder width. The length of the crank set depends on the length of the arms. Most people choose 170 mm long and 14" wide.				
Length in mms				
<input type="checkbox"/>		155 mm	Length is measured perpendicular from the centre of the crank to the centre of the hand pedal spindle.	<input type="radio"/>
<input type="checkbox"/>		160 mm		<input type="radio"/>
<input type="checkbox"/>		165 mm		<input type="radio"/>
<input type="checkbox"/>	Standard	170 mm		<input type="radio"/>
<input type="checkbox"/>		175 mm		<input type="radio"/>
<input type="checkbox"/>		180 mm		<input type="radio"/>
Width in inches				
<input type="checkbox"/>		12" (env. 305 mm)	The width is measured horizontally centre to centre to the point at the middle of the hand pedal.	<input type="radio"/>
<input type="checkbox"/>		13" (env. 330 mm)		<input type="radio"/>
<input type="checkbox"/>	Standard	14" (env. 356 mm)		<input type="radio"/>
<input type="checkbox"/>		15" (env. 381 mm)		<input type="radio"/>
<input type="checkbox"/>		16" (env. 406 mm)		<input type="radio"/>
Extra crank arms				
<input type="checkbox"/>	XLT46	Length: _____ Width: _____		£99
Crank height adjustment				
	Standard	Diagonal and vertical crank height adjustment		<input type="radio"/>
PERFORMANCE UPGRADE				
<input type="checkbox"/>	XLT60	SRM® Training System - Professional road State of the art measuring tool	Not available with 3 chainrings or a chainring less than 39 teeth. Power metre is integrated directly into the cranks.	£2,575
WHEELS				
	Standard	Threaded axles only		<input type="radio"/>
Camber				
<input type="checkbox"/>	XLT142	Camber 3°		£66
<input type="checkbox"/>	Standard	Camber 9°		<input type="radio"/>
Rear wheels type				
<input type="checkbox"/>	Standard	26" High Performance clincher wheels	With alloy rims and 14 gauge stainless steel spokes. 26" x 1" High Performance clincher tyre / tube 100 PSI	<input type="radio"/>
<input type="checkbox"/>	XLT75	26" Top End Carbon rim / stainless spokes	Tubular only - Composite rims - Spokes: 24 front and 20 rear	£1,360
<input type="checkbox"/>	XLT78	26" Top End/Spinergy® Carbon rim	Clincher only	£1,288
<input type="checkbox"/>	XLT77	Time trial package: Zipp disc rear wheels / 26" Top End Carbon front wheel	ZIPP disc rear wheels are tubular only Front wheel with carbon rim	£2,555
<input type="checkbox"/>	XLT67	Corima® AERO 26" Carbon rim	Tubular only - With carbon/graphite composite rim and stainless ovalized spokes	£2,266
Tyres				
<input type="checkbox"/>	XLT51	Continental® Grand Prix 4000 tyres	Clincher only	£91
<input type="checkbox"/>	XLT52	Continental® Sprinter tyres	Tubular only	£84
SAFETY AND COMFORT OPTIONS				
	Standard	Seat and back cushions		<input type="radio"/>
	Standard	Chain guard		<input type="radio"/>
	Standard	Drafting bumper		<input type="radio"/>
	Standard	Safety flag		<input type="radio"/>
<input type="checkbox"/>	XLT71	Tool and tyre repair kit	Incl. 22 tools in 1, a unique 3 piece design plus tyre patch kit, CO2 tyres inflators, tyre changing tools and tool bag	£56
<input type="checkbox"/>	XLT12	Mirror, legrest mount		£20
<input type="checkbox"/>	XLT63	Mirror, handle mount		£24
<input type="checkbox"/>	XLT13	Water bottle & cage		£24
<input type="checkbox"/>	XLT28	Backpack hydration system		£66
<input type="checkbox"/>	XLT141	Heart rate monitor		£66
<input type="checkbox"/>	XLT14	Cordless computer		£50
<input type="checkbox"/>	XLT9	Leg guard attachment		£50
<input type="checkbox"/>	XLT15	Helmet		£50
	<input type="checkbox"/>	Small (6 5/8" - 7")		
	<input type="checkbox"/>	Medium (6 7/8" - 7 1/4")		
	<input type="checkbox"/>	Large (7 1/4 - 7 5/8")		
<input type="checkbox"/>	XLT16	Extra safety flag		£20
<input type="checkbox"/>	XLT6	Front safety light		£17
<input type="checkbox"/>	XLT7	Rear flashing light		£17
<input type="checkbox"/>	XLT33	Alignment gauge		£50

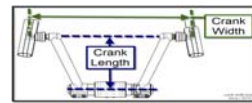

<input type="checkbox"/>	XLT40	Cable kit		£25
<input type="checkbox"/>	XLT74	Extra steering dampener		£11
<input type="checkbox"/>	XLT42	Indoor training roller		£170
<input type="checkbox"/>	TER126	Click-strap large	Pad length approx. 12"	£58
<input type="checkbox"/>	TER125	Click-strap medium	Pad length approx. 10"	£54
<input type="checkbox"/>	TER124	Click-strap small	Pad length approx. 8"	£51
<input type="checkbox"/>	RACE4	Wheel bag		£180
<input type="checkbox"/>	RACE20	Handcycle travel bag		£300
<input type="checkbox"/>	RACE13	Top End bike jersey		£62
	<input type="checkbox"/> L			
	<input type="checkbox"/> XL			
<input type="checkbox"/>	RACE22	Top End t-shirt		£9
	<input type="checkbox"/> L			
	<input type="checkbox"/> XL			
UPHOLSTERY				
	Standard	Black nylon upholstery with 2" seat and back cushion standard. Seat restraint included.		○
FRAME COLOR				
Contemporary colours				
<input type="checkbox"/>		Wet black		○
<input type="checkbox"/>		Black prism		○
<input type="checkbox"/>		White snow		○
<input type="checkbox"/>		Silver metallic		○
<input type="checkbox"/>		Stealth black		○
Way cool colours				
<input type="checkbox"/>		Royal blue		○
<input type="checkbox"/>		Midnight blue		○
<input type="checkbox"/>		Grasshopper green		○
Too hot colours				
<input type="checkbox"/>		Tangerine red		○
<input type="checkbox"/>		Raspberry red		○
<input type="checkbox"/>		Grape madness		○
<input type="checkbox"/>		Safety yellow		○
<input type="checkbox"/>		Sunkissed orange		○
<input type="checkbox"/>		Bubblegum pink		○
<input type="checkbox"/>	P1	Two colours option		£88
		Fork colour: _____		
		Frame colour: _____		

ADDITIONAL INFORMATION & MEASURING GUIDE

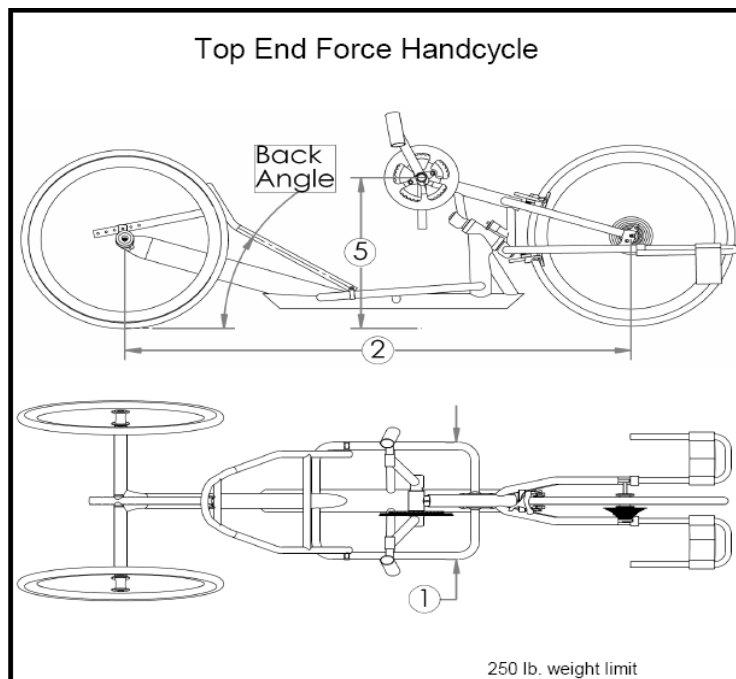

Frame: Ovalized 6061-T6 aluminium aircraft tubing with internal skeletal structure for increased stiffness
Removable fork: 6061-T6 aluminium, super stiff with adjustable crank housing
Frame design: recumbent 3 piece centreline frame construction with welded seat and adjustable back angle
Overall length: 86" (approx. 2.18 m)
Turning radius: 18 feet for 360° circle, 12 feet with one backing manoeuvre
Static tip angle: 39° for 250 lb/113Kg subject
Transfer seat height: 8" with 2" cushion (standard)
Backrest: adjustable fore and aft
Back angle: adjustable angle back of 35°-55°
Propulsion system: features a combination of Shimano and Top End components, 27 speeds, 48-39-24 chain rings and 11/34 cassette as standard. The 11/34 cassette is operated by the Hands-On Rapid Fire unit which is mounted on the right (standard) hand pedal. It operates both the 11/34 cassette and the hands-on brake. A shifter/derailleur mounted on upper crank operates the top chain rings utilizing a system which minimizes cables and their maintenance. A parking brake/second brake is mounted on the fork.
Steering: pivot steering and raked fork for controlled turning and stability
Footrest: multi-adjustable fore and aft with straps to securely cradle calves and feet. Straps are 4" wide and feature safety straps for ankles.
Assembly: shipped completely assembled except for rear wheels. Shipping weight is 65-70 lbs/29Kg - 31Kg
Warranty: 3 year on frame and fork to original owner/limited parts warranty

Invacare Ltd: www.invacare.co.uk

Pencoed Technology Park, Pencoed, Bridgend, CF35 5AQ T: 01656 776222 F: 01656 776220

All rights reserved. Trademarks are identified by the symbols ™ and ®. All trademarks are owned by or licensed to Invacare Corporation unless otherwise noted.

Shimano and Rapid Fire are registered trademarks of Shimano Inc. Spinerger is a registered trademark for Spinerger Corp.

ZIPPER is a registered trademark of Compositech, Inc. Cane Creek is a registered trademark of Cane Creek Cycling components. SRAM is a registered trademark of SRAM Corp.

SRM is a registered trademark of SRM Service Center Inc. USA. Corima is a registered trademark of Corima SA. Continental is a registered trademark of Continental Corp.

Rotor is a registered trademark of Rotor Components, LLC.

©2011 Invacare Corporation - Form No. 1107-029

